

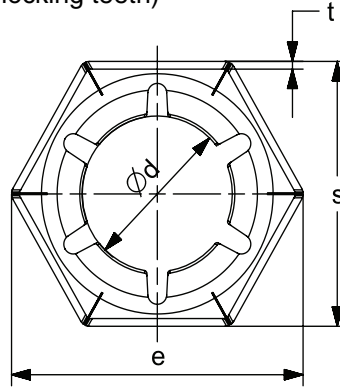

For metric thread Series 1
(6 locking teeth)

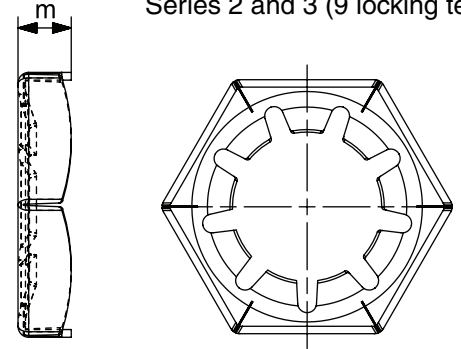

For metric fine thread
Series 2 and 3 (9 locking teeth)



Technical Specifications

| | | | |
|-------------------------|------------------------|----------|-------|
| Product Code | Item Number | 800109 | |
| Nominal thread diameter | Nom. size (series1) | M20 | |
| | Special size (series2) | M20x2,00 | |
| | Special size (series3) | M20x1,50 | |
| Diameter d1 | Serie 1 (mm) | 17,60 | |
| | Serie 2 (mm) | 18,30 | |
| | Serie 3 (mm) | 18,80 | |
| Dimensions of the hex | e (mm) | - | 34,60 |
| | s (mm) | h13 | 30,00 |
| m | Height (mm) | 6,00 | |
| Other dimensions | t (mm) | Serie 1 | 0,80 |
| | | Serie 2 | 0,80 |
| | | Serie 3 | 0,70 |
| | u (mm) | (min.) | 6,00 |
| | v (mm) | (min.) | 22,00 |

Standart
DIN 7967

Alternative Materials

-Carbon Steel C60S DIN EN 10132, hardness 420-510 Hv 10 after heat-treatment for hardening and tempering
-Stainless Steel AISI 316 (InoxA4) EN 10088, No1.4401 cold rolled at high resistance.